

RECOMMENDED PCB LAYOUT  
GENERAL TOLERANCE ±0.05

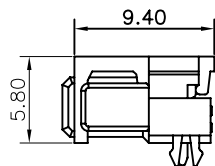
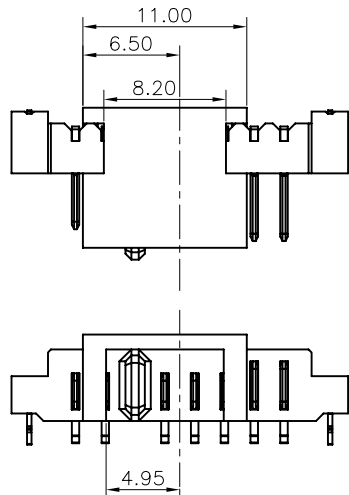
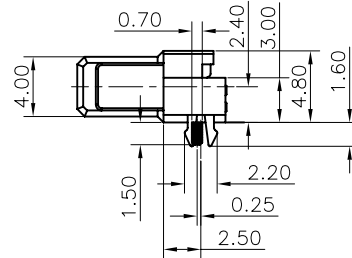
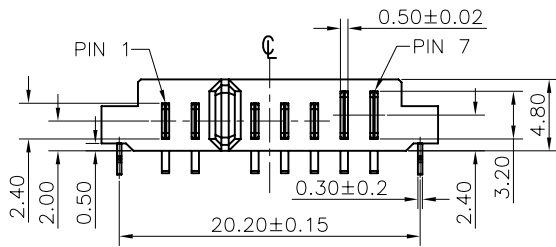

WITH COVER

NOTES:

- MATERIAL:
  - HOUSING: THERMOPLASTIC, HIGH TEMP., UL94V-0; COLOR:BLACK.
  - CONTACT: COPPER ALLOY
  - FITTING NAIL : COPPER ALLOY
- FINISH:
  - CONTACT:
    - 50~100u" NICKEL UNDERPLATING OVERALL
    - 2: GOLD PLATED ON CONTACT
  - SOLDER:
    - 50~100u" NICKEL UNDERPLATING OVERALL
    - 2:50~120u" MATTE TIN PLATING ON SOLDER AREA
  - FITTING NAIL:
    - 50~100u" NICKEL UNDERPLATING OVERALL
    - 50~120u" MATTE TIN PLATING OVERALL.
- REFLOW SOLDER CAPABLE TO 260°C PER ACES SPEC.
- WAVE SOLDER CAPABLE TO 260°C PER ACES SPEC.
- SPEC. PLS. REFER TO PS-53026-xxxxx-xxx
- PACKAGE PLS. REFER TO 53025-xxxxx-TRP

7. PART NUMBER

P/N LEGEND

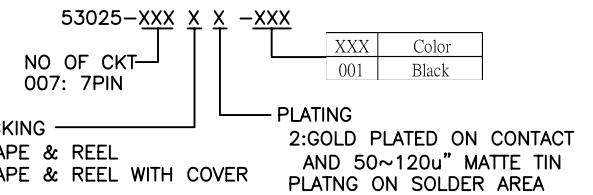

一般公差 <b>TOLERANCES</b> X ±0.50 .XX ±0.15 X ±0.25 .XXX ±0.10 ANGLES ±2°		<b>宏致電子股份有限公司</b> <b>Aces Electronic Co.,Ltd.</b>	
檢驗尺寸標示 <b>SYMBOLS</b> Ⓢ Ⓣ INDICATE CLASSIFICATION DIMENSION Ⓢ MARK IS CRITICAL DIM. Ⓣ MARK IS MAJOR DIM.	品名 (TITLE) 2.00mm Battery Conn. Male DIP R/A Type H=4.8 圖號 (DWG.NO) 53025-XXXXX-XXX	製圖 (DR) *12/04/10 許紅星 審核 (CHKD) TONY 核准 (APPD) Jason	張數 (SHEET) 1 OF 1 尺寸 (SIZE) A4 版次 (REV) 0
表面處理 (FINISH)	比例 (SCALE) 1:1	單位 (UNITS) mm	